

Single saliva collection procedure KIT package

P1101KD001



KIT - SalivaPOD™ and Copan UTM®

Saliva collection procedure KIT for PCR analysis

WHEN SAMPLING TIME, CAPACITY, PATIENT COMPLIANCE AND SENSITIVITY COUNTS

Content:

- 1 x SalivaPOD™ (CE marked)
- 1 x Copan UTM® (CE IVD marked)
- 1 x IFU paper insert (13 languages) with optional written label
- 1 x Disinfection wipe
- 1 x Absorbent pad
- 1 x ZIP-lock transport pouch

Saliva Collection Procedure KIT

Secondary packaging

- Material** Cardboard material. Outer dimensions are 73 mm x 35 mm x 142 mm
- Content** 1 x SalivaPOD™ (CE marked)
1 x Copan UTM® (CE IVD marked)
1 x IFU paper insert (13 languages) with optional written label
1 x Disinfection wipe
1 x Absorbent pad for biohazard pouch
1 x ZIP-lock transport pouch

Primary packaging SalivaPOD™

- Material** High quality foil and Flexpeel® Tyvek 2FS CR27 - Strong material supporting proper storage and use
- Blister** Blister stays open and does not return to the initial configuration after opening (no memory).
- Shelf life** Marked on the bottom of the secondary packaging box (18 months from date of UTM manufacture)
- Regulatory** CE marked acc. to MDR, Class 1, single use, non sterile. US-FDA listed device (exempt)
Manufactured in clean room, ISO 13485 certified facility.

IFU paper insert

- About** Paper Package insert with alternative sticker label 32 mm x approx 70 mm x 7 mm
- Languages** Norwegian, Swedish, Danish, Finnish, English, Spanish, German, French, Italian, Czech, Polish, Somali, Arabic

Copan UTM® 3mL

- About** Copan UTM® 3 mL 101 mm Ø16 mm laboratory tube with UTM® viral transport medium.
- Shelf life** Marked on the bottom of the secondary packaging box
- Regulatory** CE IVD marked and FDA cleared

Transport packaging - tertiary

- Material** Cardboard non bleached material. Outer dimensions are 295 mm x 260 mm x 235 mm
- Label** In the upper left corner of a short side on the tertiary box
- Content** 42 pcs of Secondary boxes

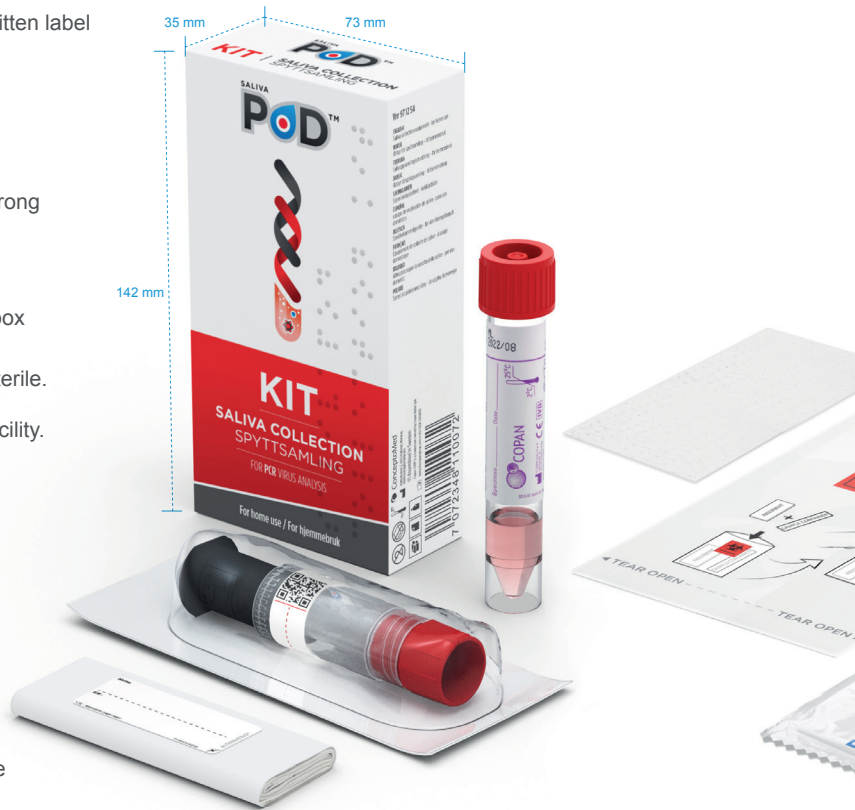

	Product description	Art.no.	Quantity HALF pallet	SalivaPODs HALF pallet	W cm	D cm	H cm	Weight (approx.)
Half-pallet	SalivaPOD™ KIT with Copan UTM™ and biohazard pouch	P1-101KD-001	48 cases x 42	2016 pcs	80	120	109	300

Full Pallets (EUR/EPAL)

Full pallet = 2 half-pallets, stacked
Size: 80 cm x 120 cm x 218 cm

- = 2 x 48 tertiary boxes
- = 2 x 2016 pcs = 4,032 pcs SalivaPOD™
- = Approximately 600 kg

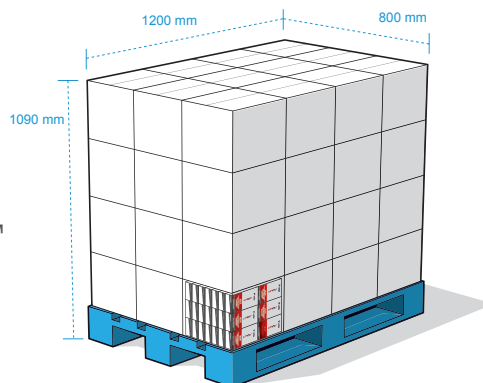

HALF PALLET SIZE